

A woman is shown in profile, riding a road bike on a paved road. She is wearing a bright pink cycling jersey and shorts with yellow accents and the brand name 'ALE' printed on them. She is also wearing a white helmet, sunglasses, and pink cycling shoes. The background features a scenic view of rolling hills and mountains under a soft, golden sky, suggesting a sunset or sunrise. The overall mood is energetic and adventurous.

ROSE
CYCLE YOUR WAY

OWNER'S MANUAL

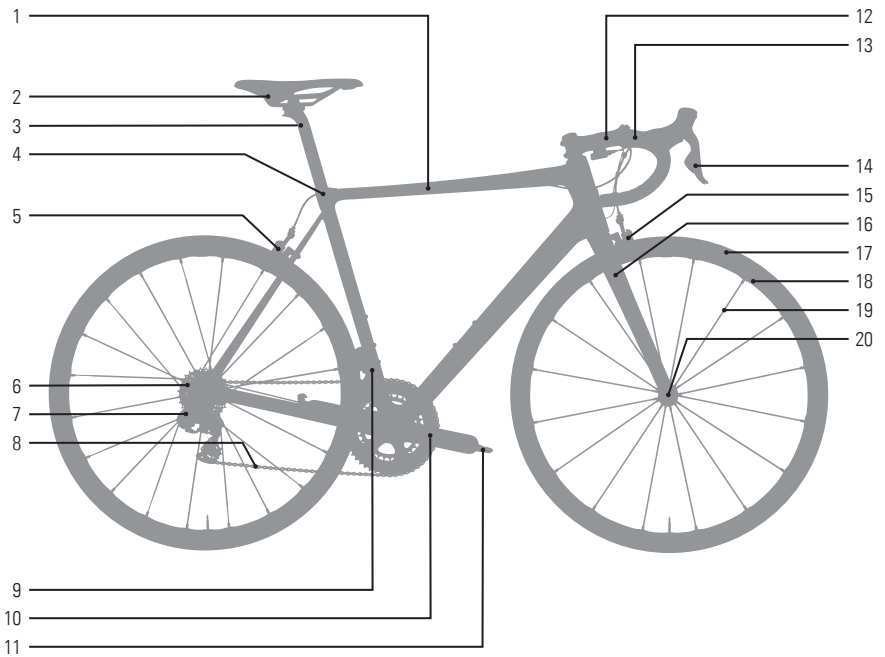

- | | | | |
|----|----------------------|----|-------------------|
| 1 | Frame | 12 | Stem |
| 2 | Saddle | 13 | Handlebar |
| 3 | Seat post | 14 | Shift/brake lever |
| 4 | Seatpost clamp | 15 | Brake caliper |
| 5 | Brake caliper | 16 | Fork |
| 6 | Cassette | 17 | Tyre |
| 7 | Rear derailleur | 18 | Rim |
| 8 | Chain | 19 | Spoke |
| 9 | Front derailleur | 20 | Hub |
| 10 | Crank with chainring | | |
| 11 | Pedal | | |

Congratulations on the purchase of your ROSE dream bike!

We are pleased that you have decided to buy a ROSE bike and are sure that your new bike will put a smile on your face every day.

Your bike is unique – before it has found its way to your home, this bike was individually assembled by hand by a skilled mechanic and carefully inspected by another specialist to ensure it meets our highest quality standards. We thus guarantee that your bike offers reliability and state-of-the-art technology. Easy-to-use gears and brakes, an excellent design and excellent value for money are just some of the reasons why you will love your bike.

Some components were removed or adjusted for shipping. However, they can be easily re-assembled or re-adjusted in just a few simple steps (see "3. Bike assembly" on page 11).

Regular care and maintenance (see "7. Maintenance" on page 29) will prolong the life of your beloved bicycle. This manual includes all information on handling, maintenance and care you need to properly care for your bike. We recommend you to carefully check and service your bike at regular intervals. Your safety and a long life of your bike should be worth the effort.

As you know, we offer a custom-made principle that allows for a variety of possible combinations of different components. Therefore, this manual only describes the most important and general facts about your bike. For more detailed information on the single components of your bike please see the respective owner's manual of the manufacturer. These are of course also included in your purchase documents.

Please take the time to read this manual carefully. The sections marked with the signal words "DANGER" and "WARNING" are of particularly high importance. The instructions contained in these warnings must be followed. Moreover, we recommend you to follow the steps described in "5. Before and after your ride" on page 23 and to have your bike serviced regularly (see "7. Maintenance" on page 29) to ensure your safety on every ride.

Have fun with your dream bike!

Your ROSE Bikes team

| | |
|---|-----------|
| 1. General information | 5 |
| 1.1 Explanation of symbols used | 5 |
| 1.2 Target group | 6 |
| 1.3 Owner's manuals supplied by component manufacturers | 6 |
| 1.4 Tools | 6 |
| 1.5 The special properties of carbon | 6 |
| 1.6 Installation of components and accessories | 6 |
| 1.7 Warranty and guarantee | 6 |
| 1.8 Wearing parts | 7 |
| 1.9 Weight limit | 7 |
| 1.10 Exclusion of liability | 7 |
| 2. Safety | 8 |
| 2.1 General safety | 8 |
| 2.2 The rider's duty of care | 9 |
| 2.3 Intended use | 10 |
| 3. Bike assembly | 11 |
| 3.1 Required tools | 11 |
| 3.2 Opening the ROSE bike box and unpacking the contents | 11 |
| 3.3 Straightening the handlebar and adjusting the steering play | 12 |
| 3.4 Adjusting the angle of the handlebar | 13 |
| 3.5 Installing the front wheel | 14 |
| 3.6 Installing seat post and saddle | 19 |
| 3.7 Installing seat post and saddle [X-LITE CW and XEON CW] | 20 |
| 3.8 Installing the pedals | 21 |
| 4. Getting started for your first ride and getting used to your new bike | 22 |
| 5. Before and after your ride | 23 |
| 5.1 Before your ride | 23 |
| 5.2 After your ride | 25 |
| 5.3 After a crash | 26 |
| 6. Bike transport and storage | 27 |
| 6.1 Transport by car | 27 |
| 6.2 Transport on a rear carrier | 27 |
| 6.3 Bike storage | 27 |
| 6.4 Bike shipping | 28 |
| 7. Maintenance | 29 |
| 7.1 Bike servicing | 29 |

1. General information

This manual is the most important element to prevent any damages and risks during the assembly, use and servicing of your new bike. It is provided to give you the most important technical information on your bike, to support you during bike assembly and to give you helpful tips over the entire life of your bicycle. If in doubt about maintenance works, please consult a qualified bicycle mechanic.

Please read this manual carefully before taking the first ride on your new bike and make sure you understand everything. Ensure that third-party users are also informed about the contents of this manual and that they understand and follow all instructions.

Keep this manual for future reference. If you sell or give away your bike, please also include the owner's manual.

This manual is additionally available as a pdf file on rosebikes.com/manuals.

1.1 Explanation of symbols used



DANGER

... indicates a hazard with a high level of risk which, if not avoided, will result in death or serious injury.



WARNING

... indicates a hazard with a medium level of risk which, if not avoided, may result in minor or moderate injury.



CAUTION

... indicates a hazard with a low level of risk which, if not avoided, may result in minor or moderate injury.



NOTE

... indicates a potentially hazardous situation that may result in damage to property.



...indicates additional information.

1.2 Target group

This manual is intended for you, the owner of the ROSE bike. Assembly and maintenance works require basic knowledge in bicycle technology. If in doubt consult a qualified bicycle mechanic. Improper assembly or maintenance of your bike may result in serious injury or death!

1.3 Owner's manuals supplied by component manufacturers

The documents supplied with your bike include this owner's manual and the manuals of the different component manufacturers. The instructions in these manuals must also be followed. The contents of those manuals will not be specifically mentioned. In case of any deviations from these instructions, the respective component manufacturer's instructions apply. The owner's manuals of single manufacturer's might only be available online.

1.4 Tools

All works on your bicycle require appropriate tools. All nuts and bolts must be tightened using the right torque wrench. Proper use prevents overtightening and breaking of the bolts.

A proper installation and removal of components can only be guaranteed when using perfectly functioning and undamaged tools.

1.5 The special properties of carbon

As most carbon frames are very sensitive to pressure, carbon frames must not be clamped (e.g. into an assembly stand) or subjected to pressure in any other way.

After an accident or fall, damages to carbon components might not show up immediately. If in doubt always seek professional advice from a qualified bicycle mechanic.

Carbon parts have a limited lifespan. Handlebars, seat posts, stems and wheels made from carbon must be replaced regularly. Please see the manufacturer's manual for the recommended intervals. We recommend to replace ROSE frames and forks made from carbon every six years.

Heat can cause permanent damage of the carbon structure. Carbon parts must not be stored close to heat sources or in a vehicle in direct sunlight.

UD carbon frames may have a blotchy and uneven surface structure. This is what characterizes the UD look. This is no defect or fault.

1.6 Installation of components and accessories

Bicycle trailers must only be fixed to the rear axle of the bike using special devices. Child seats and trailers for clamp mounting on seat post or frame must not be used.

Racks must only be attached to special fixing points designed for this purpose.

1.7 Warranty and guarantee

For all information on warranty and guarantee see [rosebikes.com/content/help/terms-and-conditions](https://www.rosebikes.com/content/help/terms-and-conditions).

1.8 Wearing parts

As a technical product, a bicycle consists of many components which are all subject to wear given the nature of their function. Therefore, the components listed below should be checked regularly and replaced, if necessary:

- Tyres and tubes
- Rims
- Brake pads
- Bearings (headset bearings, bottom bracket bearings, rear triangle bearings, hub bearings)
- Chain, cassette and sprockets
- Handlebar and stem
- Handlebar tape and grips
- Saddle and seat post
- Grease, lubricant, hydraulic oil and brake fluid
- Inner and outer brake and shift cables
- Suspension fork and rear shock
- Stickers and paintwork

1.9 Weight limit

ROSE road, cyclocross and fitness bikes are designed for a maximum weight of 110 kg. The maximum weight is derived from the weight of the rider, bicycle, gear (helmet, backpack, shoes, clothes) and luggage.



WARNING

The manuals of the component manufacturers are considered an integral part of this owner's manual and their contents must be followed!

- Consult the manual of the respective manufacturer and check the instructions for additional regulations (also see 1.3 on page 6).
- In case of any deviations, the component manufacturer's instructions apply.

Certain components might reduce the maximum system weight. Check the manufacturers' manuals for any deviations.

1.10 Exclusion of liability

The tasks described in this manual require special knowledge and should only be carried out by people with sufficient expertise.

The user is liable for damages resulting from:

- Misuse or any other cause beyond the range of the intended use (see "2.3 Intended use" on page 10)
- Non-compliance with safety regulations
- Improper assembly, repair and maintenance
- Use of unapproved replacement parts and accessories
- Change of construction

If in doubt consult a qualified bicycle mechanic or the ROSE Bike Service.

2. Safety

2.1 General safety



DANGER

Always wear a helmet!

Adapt your style of riding to your skills. Respect your limits and only ride cautiously in new situations.



DANGER

Risk of accident due to improperly installed components!

Improperly installed components can loosen during the ride!

- The installation must be carried out according to the instructions in this manual or in the manufacturer's manual.
- Consult the manuals of the respective manufacturers and check if there are any additional regulations concerning installation and torque (also see 1.3 on page 6). In case of any deviations, the component manufacturer's regulations apply. If there are no specified tightening torques, please consult the ROSE service.
- If in doubt consult the ROSE service or a qualified bicycle mechanic.



DANGER

Risk of accident due to reduced braking performance caused by brake pads that are not broken in!

Disc brakes can only achieve full braking power when the brake pads are broken in. Choose a place off public roads to break in the pads.

- Brake 20 to 30 times with the front or rear brake from a speed of 30 km/h down to 5 km/h and repeat the process for the second brake. You should brake as hard as possible without locking one of the wheels.
- Please also note the instructions of the brake manufacturer (see enclosed manual). In case of any deviations, the component manufacturer's instructions apply.



DANGER

Risk of accident due to insufficient equipment for use on public roads!

ROSE road, cyclocross and fitness bikes are not intended for use in public road traffic. If you nevertheless want to ride your bike on public roads, you will have to consult a qualified bicycle mechanic to retrofit all components required according to the national road traffic regulations (lighting system, reflectors etc.).

In Germany, all road bikes up to 11 kg are required to have at least battery-powered lights.

Outside Germany, other national regulations may apply.



DANGER

Risk of accident due to reduced braking performance on bicycles with rim brakes!

- In wet weather or when used with new wheels or new brake pads, the braking performance is reduced. Please adapt your riding style accordingly.
- Brake pads that were used with aluminium rims before must not be used with carbon rims.
- Apply both brakes at the same time.
- Do not permanently apply or drag the brake. This will cause overheating of the wheel and thus a failure of the rim, tyre or inner tube.
- When using carbon rims, the braking performance is generally lower than with aluminium rims.



DANGER

Risk of accident due to sudden total failure of pre-damaged components!

Bicycles can be subject to high stress. A fall or unforeseeable manoeuvres cause unpredictable peak loads. These loads can pre-damage components of your bike. Even though you might not immediately notice those damages, it is always possible that pre-damaged components deform or break while riding.

- Regularly check your components for damages.
- Components that are subject to high stress must be regularly replaced and checked by a qualified bicycle mechanic.



WARNING

The manuals of the component manufacturers are considered an integral part of this owner's manual and their contents must be followed!

- Consult the manual of the respective manufacturer and check the instructions for additional regulations.
- In case of any deviations, the component manufacturer's instructions apply.

2.2 The rider's duty of care

Following the instructions specified in this manual does not absolve the riders from their duty of care to ensure that their bike is always in good condition. If there are any questions consult a qualified bicycle mechanic or the ROSE service.

2.3 Intended use

The intended use of ROSE bikes is divided into five different categories – ranging from the use on paved roads through to downhill or freeride use. The bikes must only be used in accordance with their intended purpose/use. Otherwise, the user takes responsibility.

A sticker on the frame of your bike will show you the intended use.

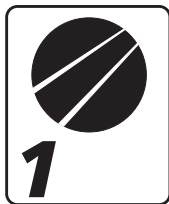

Category 1: For use on paved roads only

Category 1 includes all bikes and components that should only be used on paved roads.

The wheels will always stay in contact with the ground.



Category 2: For use on and off the road and for drops of up to 15 cm

Category 2 includes all bikes and components that can be used in conditions described under category 1, as well as on gravel roads and moderate trails. The wheels may also lose contact with the ground. Drops should not be higher than 15 cm.



Category 3: For use in rough terrain and for jumps of up to 60 cm

Category 3 includes all bikes and components that can be used in conditions described under category 1 and 2, as well as on rough trails and rough and unpaved roads that require good cycling skills. Jumps and drops should not be higher than 60 cm.



Category 4: For use in rough terrain and for jumps of up to 120 cm

Category 4 includes all bikes and components that can be used in conditions described under category 1, 2 and 3, as well as for higher speeds on rough and steep trails. Jumps should not be higher than 120 cm.



Category 5: Extreme biking (Downhill, Freeride, Dirt)

Category 5 includes all bikes and components that can be used in conditions described under category 1, 2, 3 and 4, as well as for extreme jumps and high speeds on rough trails and in bike parks.

Dirt and slopestyle bikes are not designed for use on downhill tracks.

3. Bike assembly

This chapter aims at helping you remove your bike from the ROSE bike box and re-assemble it. Depending on the bike model, different components may have been removed or repositioned for shipping. In addition, you need to fit the pedals and check if your bike is in a roadworthy condition.



DANGER

Risk of accident due to improperly installed components!

Improperly installed components can loosen during the ride!

- The installation must be carried out according to the instructions in this manual or in the manufacturer's manual.
- Consult the manuals of the respective manufacturers and check if there are any additional regulations concerning installation and torque (also see 1.3 on page 6). In case of any deviations, the component manufacturer's regulations apply. If there are no specified tightening torques, please consult the ROSE service.
- If in doubt consult the ROSE service or a qualified bicycle mechanic.



In addition to this manual, you will find some videos on how to assemble your bike at rosebikes.com.

3.1 Required tools

Depending on the bike model and the equipment, you will need the following tools for assembly:

- 4 mm, 5 mm, 6 mm, 8 mm hex keys
- Torque wrench with a 4 mm, 5 mm, 6 mm and 8 mm hex drive
- 15 mm open-ended spanner

3.2 Opening the ROSE bike box and unpacking the contents

Before opening, check the ROSE bike box for any damages. After that, check the contents for completeness! Please notify all possible defects immediately!

1. Carefully open the ROSE bike box. Make sure not to damage any parts especially when using a knife.
2. Carefully unpack the contents.
3. Remove – if present – any transport locking devices from the frame.

Keep hold of the ROSE bike box! You might need it to return the bike for servicing or repair.

3.3 Straightening the handlebar and adjusting the steering play



CAUTION

The adjusting bolt for the steering play (1) does not serve to tighten the stem, but only to adjust the play in the steering bearing!

1. Loosen the stem clamp bolt(s) (2) with a hex wrench. Do not loosen the adjusting bolt for the steering play (1).
2. Turn the handlebar through 90 degrees and align it with the front wheel.

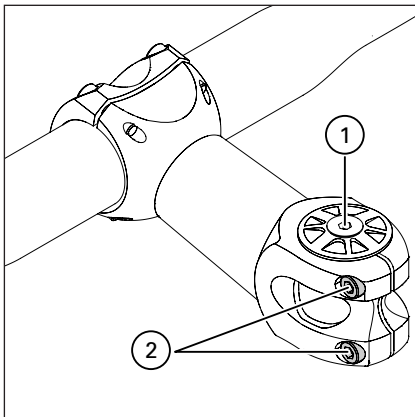

3. Check the steering bearing for play by pulling the front brake and trying to push the bike gently backwards and forwards.
→ You should not notice any play.
4. If you feel any movement inside the headset, tighten the adjusting screw for the steering play (1) a quarter turn.
5. Check the headset once again for play and repeat the previous steps until there is no more play inside the bearing. If in doubt seek professional advice from a qualified bicycle mechanic.
6. Tighten the stem clamp bolt(s) (2) alternately. For the required tightening torque see the stem of your bike or the manufacturer's manual.

3.6 Adjusting the angle of the handlebar

1. Loosen the handlebar clamp bolts by turning them anti-clockwise until the angle of your handlebar can be adjusted.
2. Check whether there is a protective film between handlebar and stem.
If there is a protective film:

- 2.1 Completely loosen the handlebar clamp bolts and remove the handlebar clamp(s).
- 2.2 Remove the handlebar and take off the protective film.
- 2.3 Re-install the handlebar and handlebar clamp(s).
- 2.4 Turn the clamp bolts clockwise and tighten them just enough so that the handlebar can still be moved.

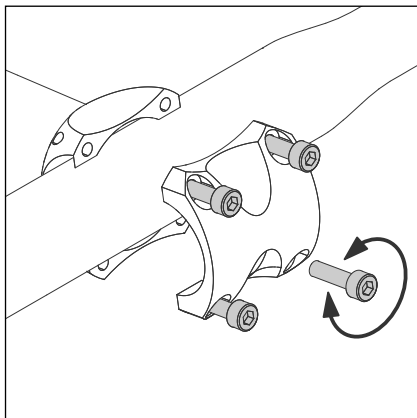

3. Centrally align the handlebar and adjust the angle.

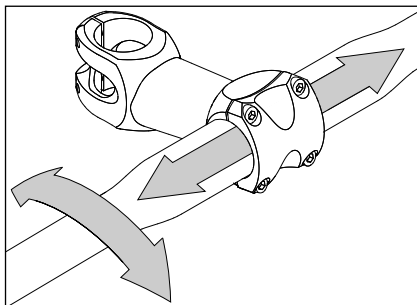

4. Tighten the bolts of the handlebar clamp alternately in small steps until you have reached the tightening torque. You can find the required tightening torque on the stem or in the manufacturer's manual.

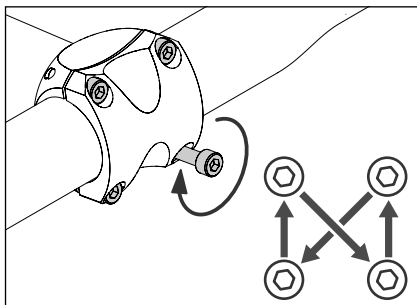

3.5 Installing the front wheel



DANGER

Risk of accident due to incorrectly installed quick release and bolt-on axles!

Incorrectly installed quick release skewers or bolt-on axles can suddenly fail while riding, which may loosen or lock the wheel!

- Quick-release axles must only be tightened by hand and without using any tools.
- In each case, check the manufacturer's manual (also see 1.3 on page 6). In case of any deviations, the component manufacturer's regulations apply.
- If in doubt consult the ROSE service or a qualified bicycle mechanic.



A bike assembly stand will help you install the front wheel. When using an assembly stand make sure to install the seat post first so that you can clamp the bike into the assembly stand at the seat post.



If there are no tyre direction marks on the wheel (e.g. disc brake or spoke magnet), please check whether the tyre has a direction arrow moulded into the side casing.

If there is neither a tyre direction mark on the wheel nor on the tyre, the wheel can be installed in any direction.

Depending on the fork manufacturer there are different systems used for installation of the front wheel.

3.5.1 Installing a front wheel with quick-release axle

1. Check whether there is an elastic band on the front brake lever. Remove the elastic band, if need be.
2. If present, remove the transport securing device that is fitted between the brake pads. Keep the locking device for future transport of your bike.
3. Remove the nut of the quick release and the spring fitted underneath.

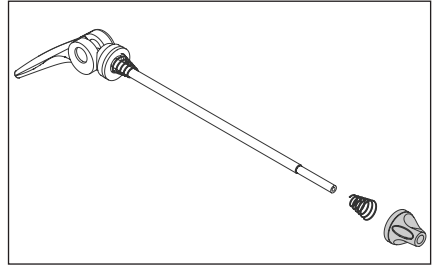

4. Check that the quick release skewer lever is in "OPEN" position.
5. Slide the quick-release axle through the hub of the wheel from the left side (in the direction of travel).

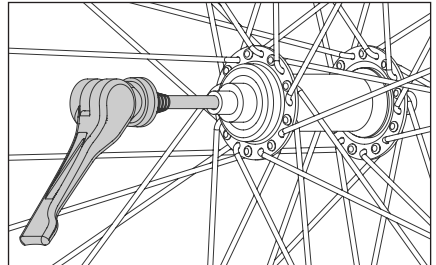

6. Put the spring back on the axle of the quick-release with the small end facing the axle.
7. Tighten the nut on the quick-release axle with around three turns.

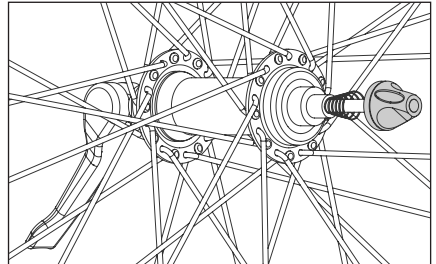

8. Open the brake caliper of the front brake. For instructions how to open the brake caliper, please see the manufacturer's manual.

9. Position the front wheel into the dropouts of the fork.
Make sure the wheel is centered in the fork.

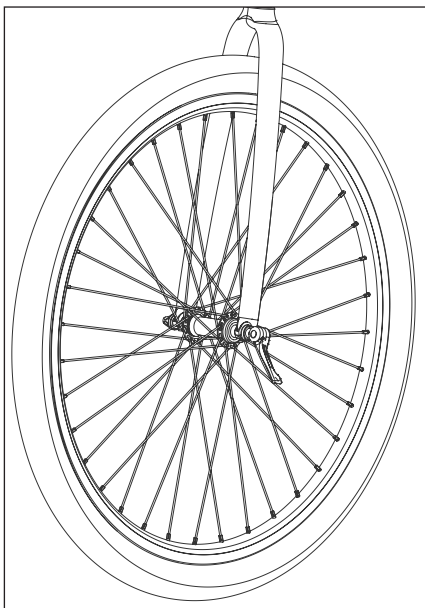

10. Move the tension lever of the quick release to the centre position.

11. Tighten the nut on the opposite side by hand.

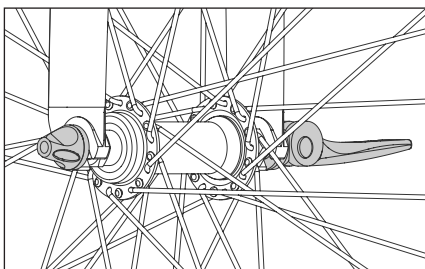

12. Now push the tension lever into the final closing position.

→ You can now see the word "CLOSED" imprinted on the lever.

→ The tension lever should only close with sufficient force.

→ If the lever tension is either too loose or too tight, you'll have to slightly loosen or tighten the nut.

Do not turn the tension lever when closed, as it might loosen. A firm connection between wheel and frame or fork can thus no longer be guaranteed.

13. Check whether the wheel fits tightly.

14. Close the brake caliper of the front brake. For instructions how to close the brake caliper, please see the manufacturer's manual.

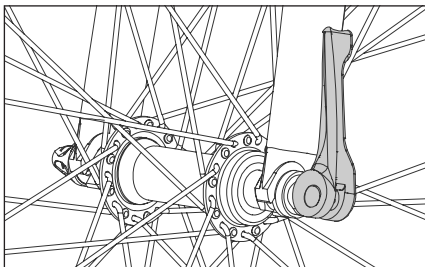

3.5.2 Installing a front wheel with DT Swiss RWS thru axle



For more detailed information on how to use the axle and for additional information see the manufacturer's manual (also see 1.3 on page 6).

1. Remove the thru axle from the fork.
2. Check whether there is an elastic band on the front brake lever. Remove the elastic band, if need be.
3. If present, remove the transport securing device that is fitted between the brake pads. Keep the transport securing device for future transport of your bike.
4. Position the front wheel into the dropouts of the fork.
5. Slide the axle through the drive side (right in the direction of travel) fork dropouts and hub of the wheel.
6. Completely thread the thru axle into the fork dropout.
7. Turn the lever clockwise and secure it by hand as tightly as possible with a minimum torque of 15 Nm.

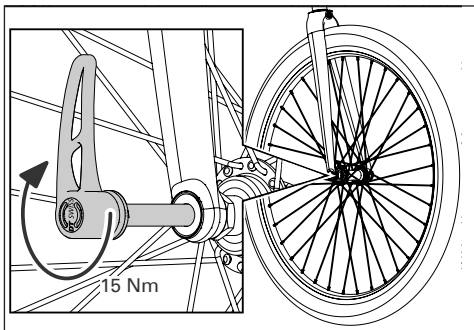

8. Lift the RWS lever (A), turn it to the required position (B) and let go (C).

Some bicycle models use a DT Swiss "RWS Plug In" thru axle. When using this type of thru axle, you can remove the lever (D). If the "RWS Plug In" is used on front and rear wheel, the bicycle will come with only one lever for both axles.

The "RWS Plug In" lever is marked with the following symbol:



9. Check if the wheel is secured correctly in the frame or fork.

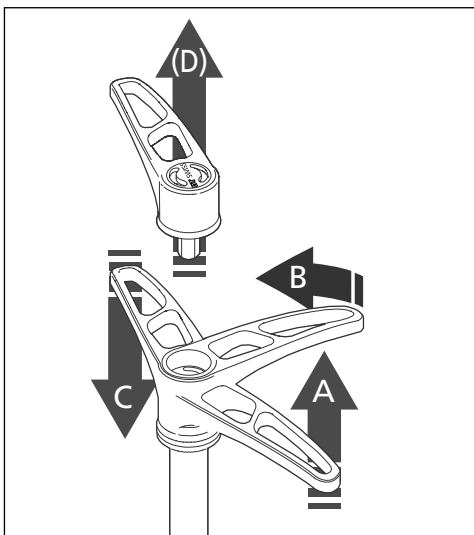

3.5.3 Installing a front wheel with Rock Shox Maxle Stealth thru axle

i For more detailed information on how to use the axle and for additional information see the manufacturer's manual (also see 1.3 on page 6).

1. Remove the thru axle from the fork.
2. Check whether there is an elastic band on the front brake lever. Remove the elastic band, if need be.
3. Remove the transport securing device that is fitted between the brake pads.
Keep the transport securing device for future transport of your bike.
4. Position the front wheel into the dropouts of the fork.
5. Slide the axle through the brake side (left in the direction of travel) fork dropouts and hub of the wheel.
6. Use a 6 mm hex wrench to completely thread the thru axle into the fork dropout.
7. Tighten the thru axle with a torque of 9 - 13,5 Nm.

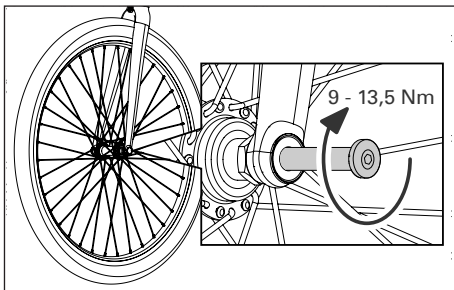

3.6 Installing seat post and saddle



DANGER

Risk of accident and damage due to the extension of the seat post beyond the minimum insertion mark!

If the seat post is not inserted to the minimum insertion mark, it may break or damage the frame while riding.

- The seat post must not be extended further than the limit mark.
- On frames with a longer seat tube that goes beyond the top tube, the seat post must be inserted even further, at least to the lower edge of the top tube.



The seat post and the inside of the seat tube are coated with grease (when using an aluminium seat post) or with carbon assembly paste (when using a carbon seat post) before installation. When installing the seat post for the first time, no additional treatment is required.

1. Remove the protective film from the seat post if present.
2. Open the seat post clamp. The clamp is either opened with a quick-release lever or with one or two bolts.

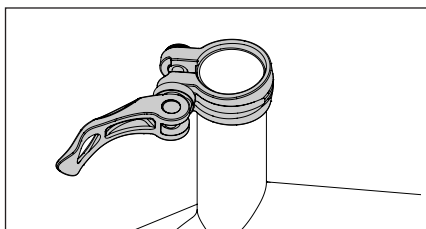

3. Carefully slide the seat post into the seat tube and adjust it to the required height. Make sure the saddle is straight.

The minimum insertion depth is marked by a limit mark and the seat post must not be lifted any higher! The seat post should at least reach the lower edge of the top tube at the seat tube/top tube crossing.

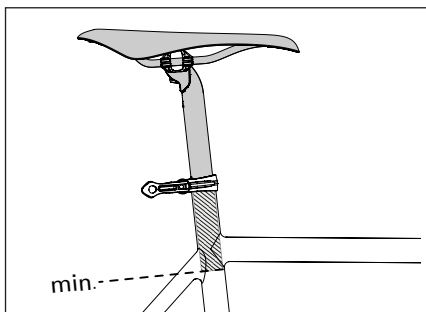

4. Close the seat post clamp.

The clamp is either closed with a quick-release lever or with one or two bolts.

- When using a bolt clamp, the required tightening torque can be found on the clamp itself or in the manufacturer's manual (also see 1.3 on page 6).
- When using a clamp with quick-release lever, the lever should be tightened by hand as tightly as possible.

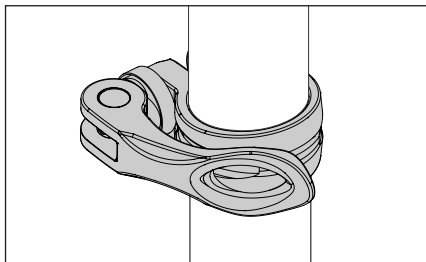

5. Get on your bike and check whether the seat post height is right.

3.7 Installing seat post and saddle [X-LITE CW and XEON CW]



NOTE

Risk of damage to the frame due to a seat post that has been inserted too deeply!

If the seat post of an X-LITE CW or XEON CW frame is inserted too deeply, the frame can be damaged.

- Insert the seat post maximally up to the lower end of the connection between seat stay and seat tube.

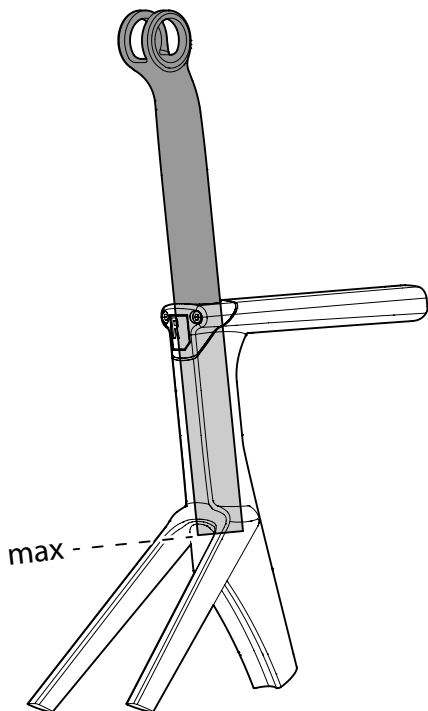

3.8 Installing the pedals



One of the pedals has a right- and the other a left-hand thread. Most pedals have the letter "L" and "R" stamped on the end of the thread. Some ROSE pedals come with a groove in the flange of the left pedal. Check the manufacturer's manual for additional marks, if there are no such marks on the pedals.

1. Check if your bike was supplied with washers and slide both washers onto the pedal axles – if present.

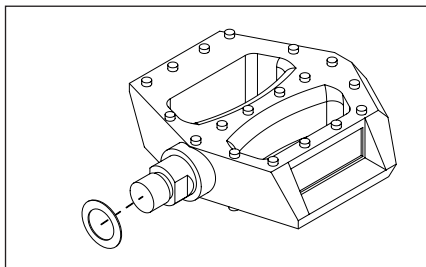

2. Turn the left pedal counter-clockwise to screw it into the thread of the left crank arm and tighten the pedal to a torque of 35 Nm.

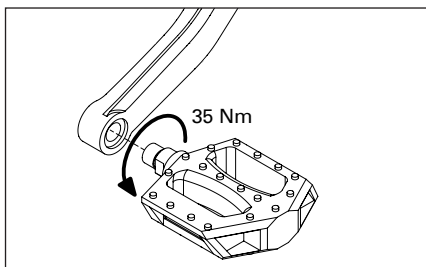

3. Turn the right pedal clockwise to screw it into the thread of the right crank arm and tighten the pedal to a torque of 35 Nm.

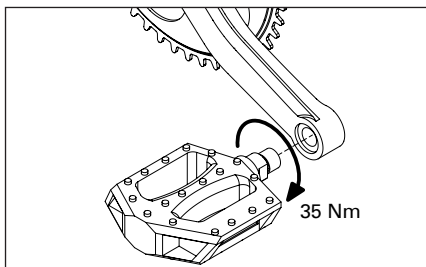

Your bike is now fully assembled. However, before you take the first ride you should follow the instructions in the chapters "4. Getting started for your first ride and getting used to your new bike" on page 22 and "5.1 Before your ride" on page 23.

4. Getting started for your first ride and getting used to your new bike

Make yourself familiar with the handling, brakes, shifting system and – if available – with the suspension elements of your bike away from public roads. Do not forget to wear a helmet! Only slowly increase the difficulty of the terrain or manoeuvres.

Requirements:

- The bike is assembled in accordance with chapter "Bike assembly" (see "3. Bike assembly" on page 11).
- The saddle height is properly adjusted to guarantee a comfortable ride and to ensure you will get on and off the bike easily.
- All tasks from the chart "Before your ride" (see "5. Before and after your ride" on page 23) have been carried out.

Disc brakes:

1. Break in the brake pads.

Choose a road away from public roads and brake 20 to 30 times with the front or rear brake from a speed of 30 km/h down to 5 km/h. You should brake as hard as possible without locking one of the wheels. Repeat the process for the other brake. Only then the brake can show its full braking power.

Please also note the instructions of the brake manufacturer (see enclosed manual). In case of any deviations, the component manufacturer's instructions apply.

Disc and rim brakes:

2. Check the functioning of the brakes while riding.



Normally, the rear brake is located on the right-hand side of the handlebar, and the front brake is on the left-hand side. However, if required, the brake levers can also be mounted the other way around.

If the positioning of the brake levers on your bike is new and unfamiliar, you will have to be careful on your first rides. Make yourself familiar with the functioning and power of the brakes while riding at reduced speed.

Many brakes offer the possibility to adjust bite point and lever reach. For this, please note the brake manufacturer's instructions (see enclosed manual).

Clipless pedals:

3. First of all, practice getting in and out of the pedals with one foot on the ground or when leaned against a wall. Only practice clipping in and out while riding after you have safely mastered the procedure while standing. The release tension of the click system can be adjusted. For this, please see the pedal manufacturer's instructions (see enclosed manual).

Shifting system:

4. Shift through all gears while riding at reduced speed and choose the right gear.

→ You can shift into all gears.

→ In the highest and lowest gear, the limit screws don't allow the chain to drop off the cassette.

5. Before and after your ride

5.1 Before your ride

To make sure your bike is safe to ride, you should carry out certain tasks before your ride. This is for your own safety in particular, yet also for your riding pleasure. Nothing is more annoying than having a defect on a bike tour.

If there are any defects or flaws, your bike must be inspected by a qualified bicycle mechanic and repaired. Never ride with a defective bicycle!

| | Task/Check | Before your first ride | Before every ride |
|--------|--|-------------------------------|--------------------------|
| Wheels | Check that the wheels are straight. Lift the wheels one after the other and spin them. → The wheels must spin smoothly. → The wheels must run true, without moving up and down or from side to side. → The tyres must not rub against the frame. | X | X |
| | Check the wheels for play in the hubs. Lift the wheels one after the other and move the wheels to the side. → There must be no play. | X | X |
| | Check the freehub mechanism of the rear hub to ensure proper engagement. Get on your bike, pull the front brake and put some power into the pedals while standing. → The power must be transferred to the rear wheel. → The freehub must not slip. | X | X |
| | Check the tyre pressure: The best way to check the pressure of the tyres is to use a floor pump with a pressure gauge. → The tyre pressure must not fall below or exceed the minimum or maximum tyre pressure indicated by the tyre or rim manufacturer. Please see the manual of the manufacturer (also see 1.3 on page 6). | X | X |
| | Check the tyres for damages and wear. → The tyres must not be damaged. → The tyres must not be worn so that the puncture protection belt or the carcass threads can be seen through the tread. | X | X |
| | Check whether the quick-releases and thru axles are properly attached. | X | X |

| | | | |
|---------------------|---|---|---|
| Brakes | <p>Check the bite point of the brakes: Pull one brake lever after the other while standing. → The bite point must be felt around half way down the brake lever travel.</p> | X | X |
| | <p>Check the braking performance: Pull one brake lever after the other while standing and push the bike backwards and forwards. → Front and rear wheel must lock when the brake lever is pulled.</p> | X | X |
| | <p>Check whether the brake pads are positioned properly when using rim brakes. → When the brakes are applied, the brake pads must be in full contact with the rim flange without touching the tyre.</p> | X | X |
| | <p>Check the brake pads for wear. → For the wear limit see the manual of the respective manufacturer (also see 1.3 on page 6).</p> | | X |
| | <p>Check the rim flange or brake disc for wear. → For the wear limit see the manual of the respective manufacturer (see also 1.3 on page 6).</p> | | X |
| | <p>Check whether the brake cables and connections are losing brake fluid and check them for defects. → Brake fluid must not escape at the connections.</p> | X | X |
| Parts | <p>Verify the tight fit of the stem: Stand in front of the bike with the front wheel between your knees. Try to turn handlebar left and right. → It should not be possible to turn the handlebar with normal force.</p> | X | X |
| | <p>Check the headset for play: Stand next to your bike with both hands on the handlebar. Pull the front brake and try to push the bike gently backwards and forwards. → You should not notice any play.</p> | X | X |
| | <p>Verify the tight fit of the seat post: Stand behind your bike, hold the saddle with one hand and try to turn it left and right. → It should not be possible to turn the saddle or seat post.</p> | X | X |
| | <p>Make sure that all parts are tight. → Loose parts must be tightened to the proper torque.</p> | X | X |
| Frame | <p>Check the frame for damages and deformation. → There must be no damages.</p> | X | X |
| | <p>Check whether all cables and hoses are in the cable clips and verify the tight fit of the clips. → All cables must fit firmly in the cable clips.</p> | X | X |
| Suspension elements | <p>Check the suspension elements (if present) for damages. → There must be no damages.</p> | X | X |

5.2 After your ride



DANGER

Brake failure or reduced braking power due to dirty brake pads or rim flanges!

Brake pads and rim flanges must be free from lubricating substances such as grease, oil (also skin oil), wax, silicon etc.! Brake pads or rim flanges contaminated in this way must not be used!

5.2.1 Cleaning your bike

After your ride you should clean your bike thoroughly using a soft cloth and clear water. Never use a pressure washer!

Stubborn dirt can be removed with a gentle cleaning agent. In this case, it is best to use washing up liquids for domestic needs. Pay attention to the notes and recommendations for use printed on the respective cleaner.

In addition, you will find numerous cleaning and care products for your bike on www.rosebikes.com.

After having cleaned your bike, you must lubricate the chain (see "5.2.2 Chain maintenance" on page 25).

If your bike comes with suspension elements, you should make sure all moving parts in this area are free from dirt. Dirt in this area may cause premature wear and thus a loss of performance of your suspension elements.

5.2.2 Chain maintenance

The bicycle chain is the most important part of the transmission. An oily chain attracts dirt and thus accelerates wear.

Please regularly follow the steps below to ensure a long and reliable service life of your chain:

1. Clean the chain with an oil-soaked cloth.
2. Lubricate the chain using chain oil.
3. Wipe away excess oil with a dry, lint-free cloth.

5.2.3 Parking your bike

Bicycles should always be protected against falling down. Especially for lightweight bikes, it is often enough to fall down from a standing position to damage the frame or components.

Please also see "6. Bike transport and storage" on page 27.



DANGER

Risk of accident due to damaged or broken components!

Crashes or exceptional stresses may cause unnoticed and invisible damages.

- Riding with damaged, bent or even torn parts is extremely dangerous.
- After a crash, the bike and its components must be checked by the ROSE service or by a qualified bicycle mechanic.
- Never fix bent parts yourself, but replace them for your own safety.

It is very hard to assess the level of damage of a carbon part. Damages cannot necessarily be seen from the outside. A scratch on the surface can indicate a delamination (a separation of the single carbon layers).

Especially for lightweight bikes, it is often enough to fall down from a standing position to damage the frame or components. When suspecting a damage, you should always consult the ROSE service or a qualified bicycle mechanic.

Damages on aluminium parts are indicated by dents, cracks, deformations or discolorations. If you notice any sign of damage, the component or bike must no longer be used. When suspecting a damage, you should always consult the ROSE service or a qualified bicycle mechanic.

6. Bike transport and storage

6.1 Transport by car

The best and safest way to transport your bike is by car. Here, your bike is perfectly protected from the elements and from theft. Yet there are some things you should bear in mind:

- When exposed to direct sunlight, surfaces can get very hot inside a car. Carbon parts must be covered or protected from direct sunlight.
- Carbon parts are extremely sensitive to pressure. When stacking up parts, e.g. putting wheels onto a frame, the parts must be well padded. Many manufacturers offer special wheel bags for their wheels. In this way, the wheels are perfectly protected during transport.
- When removing the wheels, you must fit a transport lock between the dropouts of the frame or fork.

6.2 Transport on a rear carrier

Rear bike carriers with clamps for top, down or seat tube are not suitable for carbon frames. The clamping force of the clamps may damage the carbon structure.

Rims must be padded before fitting lashing straps or ratchet systems.

When transporting several bikes with one rear cycle carrier, please make sure that there is sufficient distance or padding between the bikes.

If you use carbon wheels, please make sure that there is enough distance between the exhaust pipe and the wheel. The minimum distance is 45 cm behind the exhaust pipe and at least 20 cm on top.

Please also note the instructions of the bike rack manufacturer.

6.3 Bike storage

You should park your bike using an appropriate cycle stand which ideally only holds the rear wheel. Make sure to check the tyre pressure when the bike has stood for a long time. You should not park your bike for longer with no air in the tyres.

Another alternative for the secure storage of your bike is to hang it onto a hook that is padded or covered with plastic or rubber. Only bikes with deep-section rims made from carbon must not be stored in this way.

If you use a tubeless system, you should remove the sealant from the tyre when parking your bike longer than three months. Some sealants contain ingredients that increase corrosion and could thus damage the rim.

6.4 Bike shipping



Depending on the size of the ROSE bike box, the bike is shipped in different conditions. Always ship the bike in the condition you have received it.



1. Secure or cover all loose or moving parts properly. Sharp or pointed components have to be wrapped additionally to make sure they won't damage other parts of your bike and won't tear through the outer packaging.
2. If your bike was delivered with a removed front wheel, the front wheel should also be removed for shipping now. Wrap the front wheel with a cardboard. This will also protect the handlebar and top tube of your bike.
3. If the wheels need to be removed, you must pack away the quick-releases separately. Thru axles must be screwed into the dropouts.
4. Position the cardboard at the rear on the side of the rear derailleur.
5. Protect the top tube from damages through the handlebar by using appropriate material (e.g. foam tubing).

7. Maintenance

Regular care and maintenance will prolong the life of your new bicycle. You should carry out easy cleaning, servicing and repair tasks yourself (see "5. Before and after your ride" on page 23).

7.1 Bike servicing

Servicing is required after a specific period of time or after a certain amount of kilometres ridden, whichever comes first. The service must be performed by a qualified bicycle mechanic.

Service intervals

- 1. servicing after 500 to 1000 km, six months after purchase date at the latest
- 2. servicing after 3000 to 4000 km or two years after purchase date
- 3. servicing after 5000 to 7000 km or three years after purchase date

The following tasks must be carried out:

| Task | 1. Servicing | 2. Servicing | 3. Servicing |
|--|--------------|--------------|--------------|
| Visual inspection of all components | X | X | X |
| Check of all bearings and screw connections | X | X | X |
| Check of spoke tension | X | X | X |
| Wheel truing | X | X | X |
| Adjustment of gears | X | X | X |
| Adjustment of brakes | X | X | X |
| Check of chain, brake pads and tyres for wear and replacement, if necessary. | | X | X |

